



# FTTP MDU Survey



**openreach**

Connecting you to your network

Template Version: 5.0

## FTTP MDU Survey



Estimate No.	<b>WD3V238L</b>	Exchange:	EDINBURGH WAVERLEY	MDU ID	SM-00002658
Surveyor	<b>Thomas.Duff</b>	Contact No:	<a href="mailto:Thomas.Duff@kngroup.com">Thomas.Duff@kngroup.com</a>	Completion Date	
Planner	LEANNE GULLIFORD	OUC:	MDUS SURVEY	Project No.	GRKKO
Certified as Correct:		Date	27/04/2022		

### Gold Standard Page Guide - Contents

Supplier Turnkey:

No

Mandatory	Task Completed	Tab	Template Tab Used	Provider Responsibility
Yes		1	Job Notes	Openreach
Yes	Yes	2	OS Map	Openreach
Yes	Yes	3	Equipment Diagram	Openreach
Yes	Yes	4	Duct Diagram	Openreach
Yes	Yes	5	TMA	Openreach
Yes	Yes	6	NAD Address List	Openreach
Yes	Yes	7	Building	Supplier
Yes	Yes	8	Covid-19 Risk Assessment	Supplier
Yes	Yes	9	Hazard Identification	Supplier
Yes	Yes	10	Listed Buildings & Method of Feed	Supplier
Yes	Yes	11	Asbestos Information	Supplier
Yes	Yes	12	Rod & Rope	Supplier
Where Required	Yes	13	A55	Supplier
Yes	Yes	14	Floor Plan	Supplier
Yes	Yes	15	Survey Template	Supplier
Yes	Yes	16	Schematic Template	Supplier
Yes	Yes	17	Cable Route	Supplier
Yes	Yes	18	Bill of Materials	Supplier
Yes	Yes	19	FIRAS Certification	Supplier
Yes	Yes	20	Build Guidance	Supplier
Yes	Yes	21	Components	Supplier
Yes	Yes	22	InvisiLight	Supplier
Yes	Yes	23	EZ Bend	Supplier



<b>Job Notes</b>		
<b>openreach</b>	<b>NGA PLANNINGSTANDARD JOB PACK</b>	<b>Job Description</b>
		NGA_FTTTP_EH/WAV_(Flats 65/1 to 65/10)_Holyrood Road
<b>JOB TYPE</b>	<b>FTTP MDU – INTERNAL SURVEY PACK</b>	<b>Access Details</b>
MDU ID	SM-00002658	Charlie Leask - 0131 346 8989 - c-leask@ross-liddell.com
UPRN	906403396	<b>Customer Requirements / Job Notes</b>
ORWFMT Project ID	GRKK0	
Customer Type	Residential	
GRID REF	326,537,673,672	
NIMS No.	23999474	
Customer	Openreach	
Site Address	65/1 - 65/10, Holyrood Road, Edinburgh, EH8 8AU	
Planning Contact	PRAVEEN MURALI	<b>Fibre City:London</b>
Planners Telephone No.	6501500 (PSTN 020 8726 1500)	<b>THP: 10</b>
Planner's Email Address	<a href="mailto:praveen.murali@openreach.co.uk">praveen.murali@openreach.co.uk</a>	
Property Agent / Manager / Owner	Ross & Liddell Ltd, 60, St Enoch Square, Glasgow, G1 4AW	<b>Wayleave Obtained:Not yet secured</b>
Telephone No.	1313468989	
Highway Authority	City of Edinburgh	
Principal USRN	7901866	
<b>Associated Estimates</b>	<b>Estimate No (s)</b>	<b>Comments</b>
<b>Governing</b>		
<b>Concurrent</b>		

Dependent

Works Instructions / Job Notes / NR&SWA Conditions

CARRY OUT FULL SURVEY.  
OBTAIN WAYLEAVE AS APPROPRIATE.  
CAPTURE GRANTORS NAME AND CONTACT DETAILS AND EMAIL ADDRESS.  
POSITION WITHIN COMPANY.

The work requested on this pack is to prepare the MDU SOLUTIONS property for the NGA network. This is part of the FTTP (Fibre To The Premise) Overlay Fibre cities project. It is important that this work is completed on the dates requested.

Survey suitable cable routes and equipment locations, to serve all addresses within the MDU. Consider the location of cable and equipment for access at installation/repair and the suitable MDU solutions.

Please use Openreach Standard Survey Pack, including works instruction diagram (A55) Survey if lead-in is ducted to the premises. Check the total number of DWs/blocks/ and furniture on any pole and for any line of sight issues.

Please provide a PowerPoint file containing images of the property showing;

Front View

Left View

Right View

Rear View (If possible)

Clear internal duct view of feed to (showing all Ducts)

Clear internal view of all duct entry, risers and stairwells on route to the proposed equipment

Image of proposed MDU equipment location, clearly showing the exact location in the highway

PLEASE WORK THROUGH MDU SURVEY REPORT AND PROVIDE REQUESTED INFORMATION

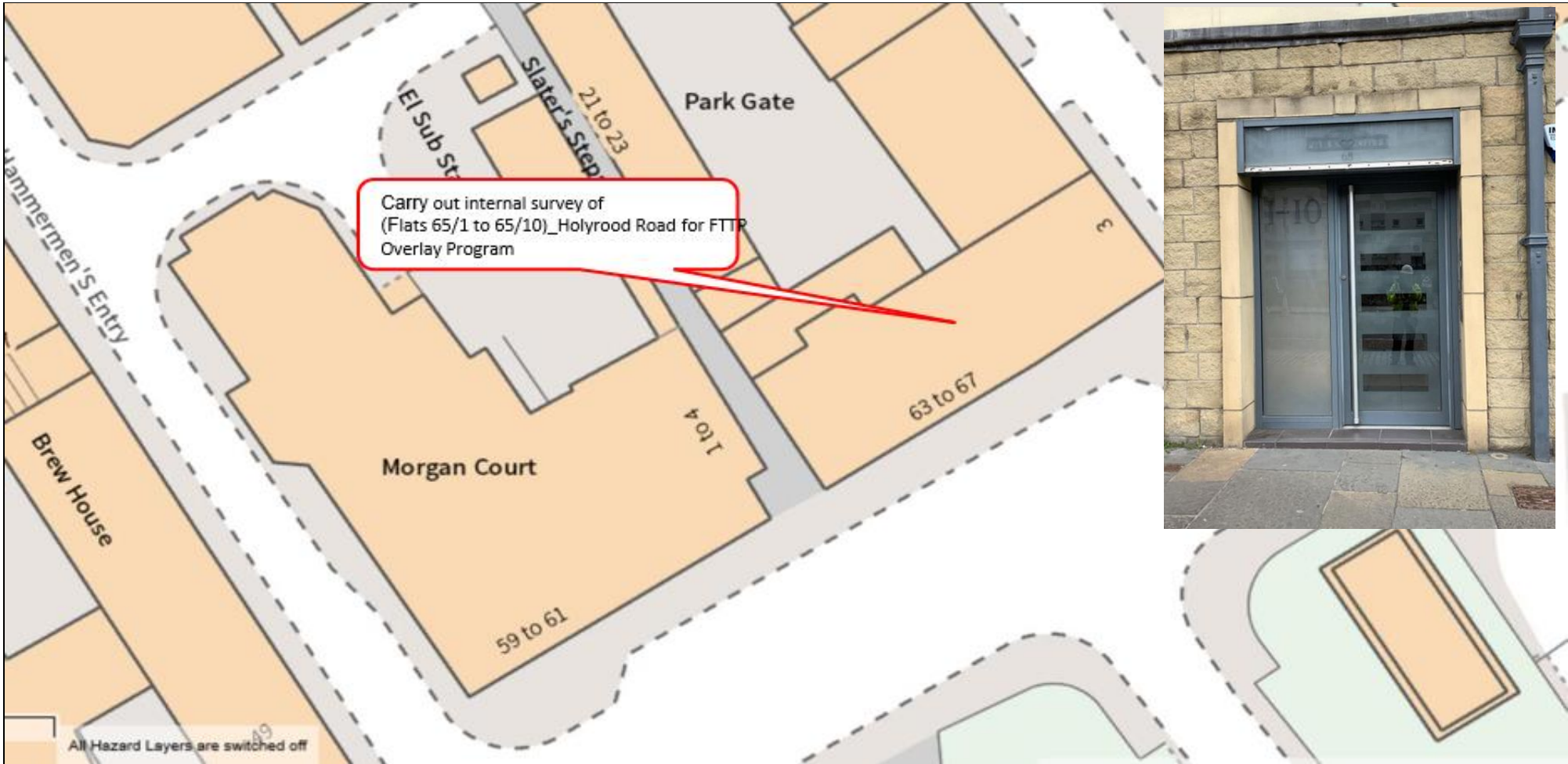

Notes:

openreach  
Connecting you to your network

circet  
UK

OS MAP

Planned by:

LEANNE GULLIFOR

Date

27/04/2022

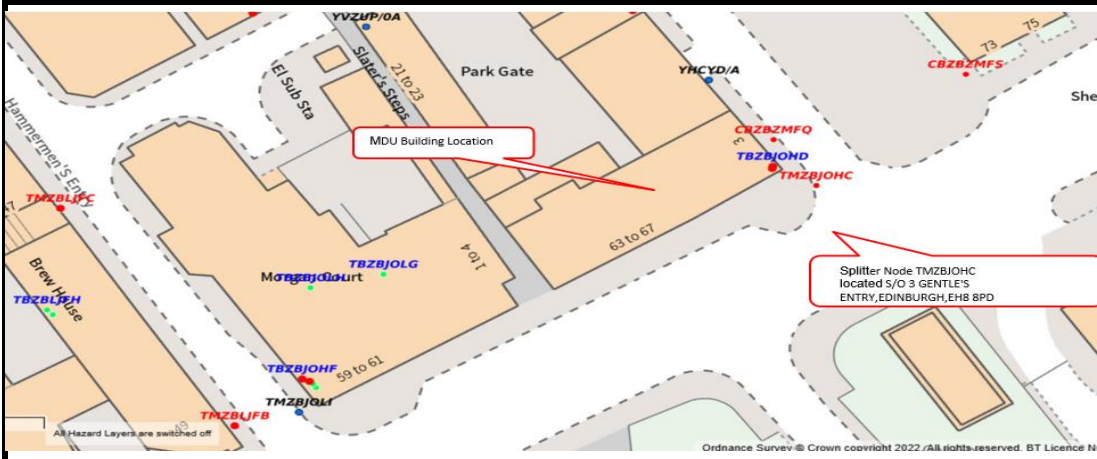

Exchange Name	EDINBURGH WAVERLEY
---------------	--------------------

TM Node / Joint:	TMZBJOHC
------------------	----------

Is the node available at provided location:	NO
---	----

If not provide details:	
-------------------------	--

Notes: but unable to confirm node as JRC is on road and unable to open, requires lifter and TMA

Key:

Item	External		
	Proposed	As built	Existing
Fibre Cable			
External U/G Joint			
Underground Duct			
Chamber			
Riser guard			
Catenary Wire			
Toby			
Riser			

Schematic	
Item	Proposed
Joint	
Basement Box	
Budi Box	
Chamber	
RDT	
CSP	
CBT	



Planned by:	LEANNE GULLIFORD
Date	27/04/2022

Floor Plan

UPRN	SN	NAD Key	Building Name	oroughfare Name	Town	Postcode	Floor	FDP Number
906127947	ESWAV_18_SN_62	A15098671193	65/1	HOLYROOD ROAD	EDINBURGH	EH8 8AU	1	FDP1
906127948	ESWAV_18_SN_62	A15102842641	65/10	HOLYROOD ROAD	EDINBURGH	EH8 8AU	5	FDP1
906127949	ESWAV_18_SN_62	A15098546735	65/2	HOLYROOD ROAD	EDINBURGH	EH8 8AU	1	FDP1
906127950	ESWAV_18_SN_62	A15098671195	65/3	HOLYROOD ROAD	EDINBURGH	EH8 8AU	2	FDP1
906127951	ESWAV_18_SN_62	A15098546737	65/4	HOLYROOD ROAD	EDINBURGH	EH8 8AU	2	FDP1
906127952	ESWAV_18_SN_62	A15098546738	65/5	HOLYROOD ROAD	EDINBURGH	EH8 8AU	3	FDP1
906127953	ESWAV_18_SN_62	A00063247540	65/6	HOLYROOD ROAD	EDINBURGH	EH8 8AU	3	FDP1
906127954	ESWAV_18_SN_62	A15098671199	65/7	HOLYROOD ROAD	EDINBURGH	EH8 8AU	4	FDP1
906127955	ESWAV_18_SN_62	A15098546740	65/8	HOLYROOD ROAD	EDINBURGH	EH8 8AU	4	FDP1
906127956	ESWAV_18_SN_62	A15098510300	65/9	HOLYROOD ROAD	EDINBURGH	EH8 8AU	5	FDP1



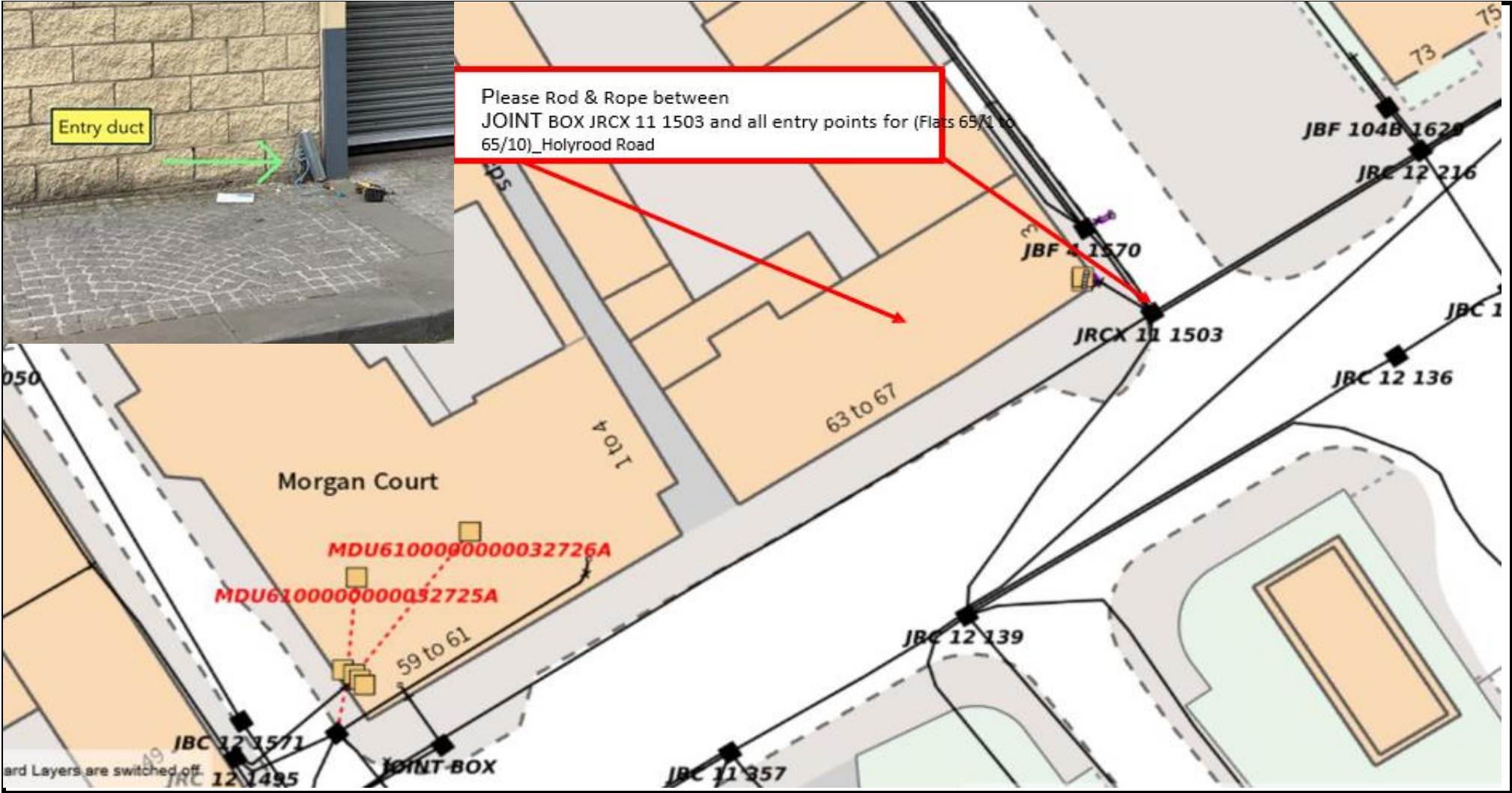

Notes:

 	
Planned by:	LEANNE GULLIFORD
Date	27/04/2022

Duct Diagram

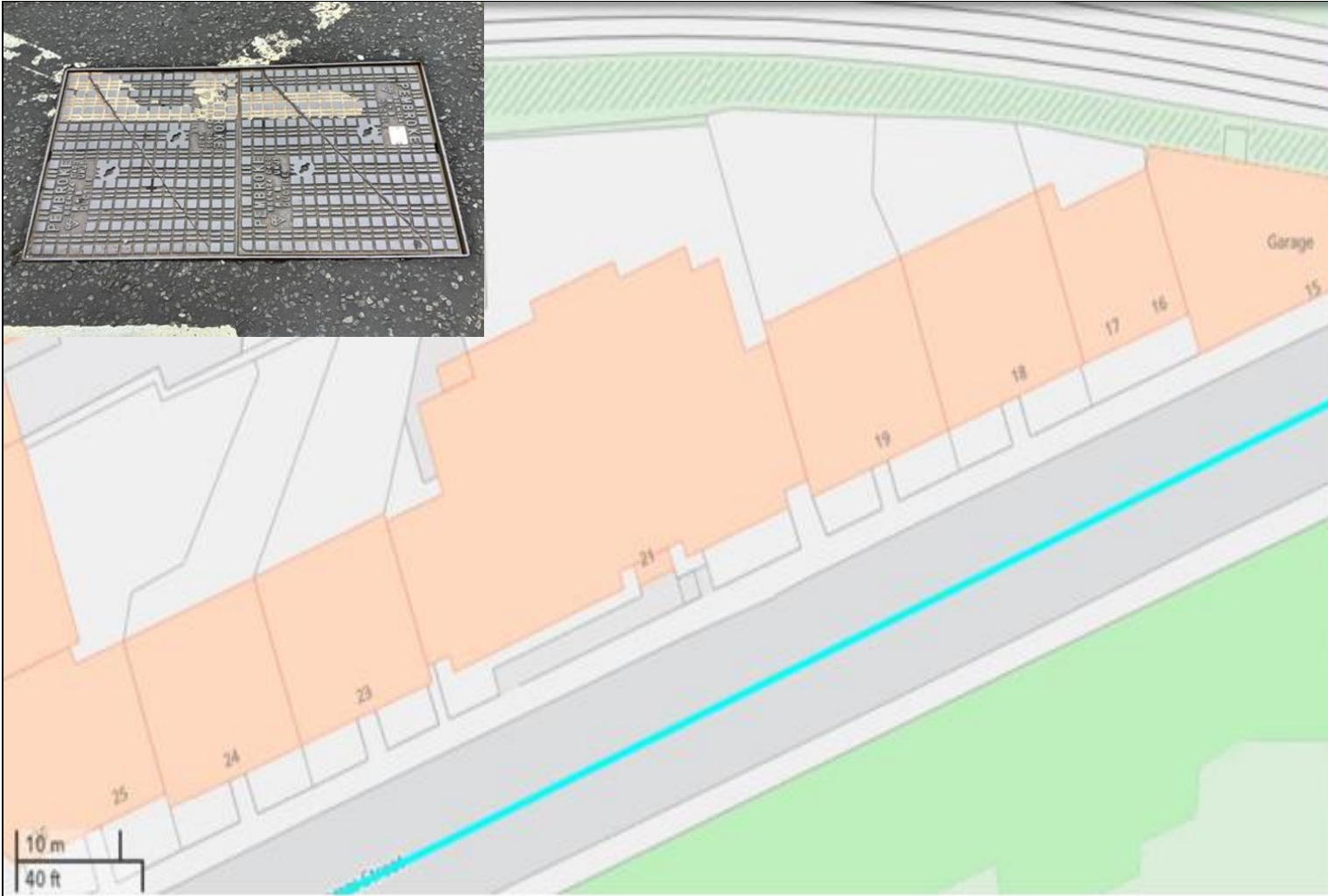

View

**Road**  
Balcarres Street, Easter Craiglockhart, Edinburgh

**Asset Details**

USRN  
07904505

Maintaining Authority  
City of Edinburgh Council (9064/1)

**Address**  
Balcarres Street  
Easter Craiglockhart, Edinburgh, Edinburgh

Road Type  
Designated Street Name

State  
-

Street Status

---

Special Designations (5) +

**Notes:**

TRR looks to be done already but unable to complete as JRC is on road and unable to open, requires hydraulic lifter and TMA

Planned by:	LEANNE GULLIFORD
Date	27/04/2022

TMA



Notes:

Front of building

openreach  
Connecting you to your network

circet  
UK

Building

Planned by:

LEANNE GULLIFORD

Date

27/04/2022

Covid-19 Risk Assessment



65/1 - 65/10, Holyrood Road, Edinburgh, EH8 8AU



**Project** Openreach MDU  
**Planner** LEANNE GULLIFORD

27/04/2022

ID	Ref	Identified Hazards and Associated Risks	Control Measures		Yes/No
1	Risk of Contamination	Potential exposure to COVID-19	<p>No work will be undertaken by an engineer/operative who has symptoms of COVID-19 (High temperature, a new continuous cough or a loss/change to sense of smell or taste)</p> <p>Our regional roving supervisor shall during the works ensure that operatives are following social distancing and hygiene guidance in accordance to the current regulations. If the supervisor feels the work area cannot be suitable managed operatives shall not enter a dwelling work will not commence and the issue will be escalated to the 'project manager/ desk team or H&amp;S Department'</p> <p>Prior to attending a site the desk team shall contact the relevant managing agent/site contact to ascertain the following information;</p> <ol style="list-style-type: none"> <li>1, Is there anyone that they are aware off within the building that is suffering from COVID-19 symptoms, or vulnerable persons?</li> <li>2, Are you aware of anyone that is shielding?</li> <li>3, Are you aware of any external visitors due during the time of works that you are aware off(i.e. care workers etc.)?</li> <li>4, Have the residents been informed that the work is taking place and requested to limit their movement during this time?</li> <li>5, Are you happy with the proposed safe system of work?</li> <li>6, Is there any welfare that we could be permitted to utilise during the works?</li> </ol> <p>Resource will also ensure there is good ventilation in the area they working by opening a window is permissible.</p> <p>Disposable gloves and disposable face mask will be worn at all times onsite. Guidance on the safe removal of gloves and masks has been provided from Virtua Covid-19 awareness that all resource shall be briefed on prior to undertaking work on the contract.</p> <p>Use disposable glove when required to handle items that may be contaminated. Ensure disposable gloves are removed from the cuff and turned inside out as they are removed to prevent further contamination. All single use items of PPE shall be disposed of via a double bag method and removed from site.</p>	<p>Engineers must maintain social distancing space of two meters (where possible) avoid touching your face, wash hands frequently, use hand sanitiser frequently, use disposable latex gloves when handling equipment, follow good respiratory hygiene by covering your mouth and nose with your bent elbow or tissue when you cough or sneeze.</p> <p>Then dispose of the used tissue immediately into your issued Hazardous waste bags (reapply hand sanitiser) once works complete remove from site for correct disposal.</p> <p>All operatives and the supervisor shall don PPE in accordance to the Virtua Covid-19 briefing document (before entering the premises).</p> <p>This will as a minimum be; facemasks, hi viz (with 2metre apart logo on rear), gloves and overshoes.</p>	YES

2	Unnecessary exposure to the virus due to lack of awareness	Potential exposure to COVID-19	<p>All operatives have reviewed the Virtua Covid-19 briefing document</p> <p>The regional supervisor will have been provided with specific guidance regarding the management of the workforce to ensure the risk of contamination and exposure is mitigated.</p> <p>Working in Communal areas - enhanced cleaning procedures to be followed across the site, particularly in communal areas and at touch points including:</p> <ol style="list-style-type: none"> <li>1. Taps and washing facilities.</li> <li>2. Toilet flush and seats.</li> <li>3. Door handles and push plates.</li> <li>4. Handrails on staircases and corridors.</li> </ol>	<p>All engineers regularly receive bulletins and toolbox talks regarding COVID-19 and safe working practices from Virtua</p> <p>The workforce should stay on site once they have entered it and not use local shops. Bringing your own food and drink from home is the sensible choice rest period can be taken in your own vehicle on site.</p>	YES
3	Handling of potentially contaminated materials (Tools, Touch points, work surfaces etc)	Potential exposure to COVID-19	<p>Only essential tools and equipment will be brought onto site, they will be cleaned with sanitising wipes before and after use, if tools are shared, they must also be cleaned before and after use.</p> <p>Engineers to ensure any surface they come into contact with is sanitised/wiped down using issued hand wipes before and after the works.</p> <p>Engineers are to also ensure all key touch points are sanitised before and after use. Use wipes or other methods of sanitising equipment before you handle it. Where facilities to wash hands are not available, hand sanitiser will be used, and the engineer will always carry this with them.</p>	<p>COVID-19 hygiene measures will be applied as per Government and Virtua guidance. This includes, outside the property, and prior to entry, the engineer will wash their hands using soap and water for 20 seconds or hand sanitizer. They will wash their hands regularly, particularly after blowing their nose, sneezing or coughing, and when leaving the property</p>	YES
4	Members of the public in close proximity (Including visitors)	Potential exposure to COVID-19	<p>If residents want to pass the working area the Supervisor/lead engineer. is to instruct the operative/operatives to adjust the work area ensuring there is a suitable gap between the worker and resident to enable safe passage.</p> <p>Engineer is to turn away from the occupant/resident when they are transitioning through the area.</p> <p>Once occupant/Resident has passed through the work area location the Engineers is to reinstate barriers and proceed with works.</p>	<p>The Supervisor/lead engineer is always to monitor the working area and must usher the residents/members of the public in a timely manner to ensure safe passage in line with current guidance.</p>	YES

5	Compliance with existing emergency procedures	Potential exposure to COVID-19	<p>Engineers must confirm with the building representative if there any planned fire drills scheduled during the duration of works.</p> <p>Engineers must ensure good housekeeping practices at all times to ensure walkways/hallways are clear from obstruction.</p> <p>In case of fire operative is to ensure that all Barriers are moved to a safe distance i.e. placed against the wall with all feet pushed to the side as not causing a trip hazard or blocking any means of escape routes for residents in case of evacuations from the building.</p>	<p>Fire assembly point must be identified before commencement of any working activity.</p> <p>Engineers are to ensure that Covid-19 Signage is placed at the entrance to the building and at any entrance points to the Hallways/communal areas</p>	YES
6	Manual handling	Potential exposure to COVID-19	<p>All Virtua operatives have undergone manual handling training.</p> <p>Where necessary, manual handling work or transport of loads, is to be isolated from members of the public by use of cordons and/or barriers.</p> <p>A site-specific ergonomic assessment will be conducted prior to any manual handling exercise taking into consideration the following:</p> <ul style="list-style-type: none"> <li>* Task.</li> <li>* Individual capability.</li> <li>* Load.</li> <li>* Working environment (safe route with consideration given to ensuring pathways are free from obstacles and slip/trip hazards, lighting etc.)</li> <li>* Other factors (e.g. use of PPE, required breaks etc.)</li> </ul>	<p>Where possible manual handling will be eliminated Through the use of mechanical aids e.g. Forklift, trolleys etc. (inspected before use).</p> <p>Transport required equipment to work area utilizing lifts where available (One man at a time), The supervisor is to monitor this activity to ensure social distancing guidance is adhered to.</p>	YES
7	Welfare	Potential exposure to COVID-19	<p>Operations/desk team team to ascertain with building manger if there are any welfare facilities available to the Engineers on site prior to attendance. If the answer is no then the following will be in place:</p> <ol style="list-style-type: none"> <li>1. Engineer has access to bottled water and hand soap</li> <li>2. Engineer has access to Hand Sanitiser</li> <li>3. Engineer has access to anti-bacterial wipes</li> </ol> <p>Engineer is to ensure these areas are wiped down with anti-bacterial wipes before and after entry and is to ensure you wash your hands.</p> <p>All Engineers/operatives must follow the, PHE Guidelines on COVID 19 hygiene.</p> <p>If welfare facilities are available, then before and after use a thorough clean and wipe down of any surfaces touched by the Engineer must be completed.</p> <p>Engineers/Operatives and Supervisor are to book confirm attendace to site</p> <p>On completion of works Engineer/Operatives and Supervisor are again contact 'desk team/Project manager' when works are completed.</p> <p>Operatives/Engineers will only work in Hallways, Communal areas and stairwells.</p>	<p>Eating arrangements-</p> <p>Engineers must stagger their work break and come prepared with provisions to limit the requirement to leave site. Engineers are to take welfare breaks in their own vehicles where welfare unit is not available.</p> <p>Vehicles-</p> <p>Vehicles must be wiped down before and after entering them particular attention being paid to all touch points.</p> <p>Before you get into your vehicle the driver, you should wash your hands thoroughly. Before using your vehicle, you should wipe down the door handles, steering wheel, gear stick and all other frequently used controls, including the touchscreen, with disinfectant wipes.</p>	YES
<p>Planner Name      Completed the above hazard identification sheet in relation to the planned works and surrounding area, based upon the findings during site survey and any guidance from third parties. Further risk assessment may be required.</p>					

Hazard Identification



65/1 - 65/10, Holyrood Road,  
Edinburgh, EH8 8AU





Project Planner		Openreach MDU LEANNE GULLIFORD	Date	27/04/2022
Hazard ID	Hazard	Possible Locations/People affected	Yes/No	Minimum Requirements
1	Impact on access for emergency services	Hospital Entrance, Ambulance Station, Fire Station, Police Station	Yes	Provide NRSWA, Chapter 8 signing and guarding. Adequate barriers and equipment on site. Liaise with local residents/emergency services. Clean High Vis PPE worn at all times on site. Further risk assessment may be required taking into consideration access for emergency vehicles at all times.
2	Children from Schools, Colleagues, University etc, getting access to the site (falling into trenches, interfering with equipment, guarding)	Schools, Colleagues, University, Nurseries, Playground etc.,	Yes	Permission to be granted by school headmaster before works commence. Provide NRSWA, Chapter 8 signing and guarding. Ensure equipment/vehicles are made safe before leaving unattended. Good Housekeeping on site. Undertake works during holidays / weekends
3	Pedestrians visiting Doctors Surgery, Health Centre, getting access to the site (falling into trenches, interfering with equipment, guarding)	Doctors Surgery, Health Centre	Yes	Provide NRSWA, Chapter 8 signing and guarding. Ensure equipment/vehicles are made safe before leaving unattended. Good Housekeeping on site. Further risk assessment may be required taking into consideration necessary temporary structures if our works will disrupt / temporarily put out of service specific requirements i.e. ramps
4	People falling into excavations. People falling over Barriers	All sites; Pedestrians including blind / partially Sited Persons, physically Disabled Persons, old persons.	Yes	Provide NRSWA, Chapter 8 signing and guarding. Adequate barriers and equipment on site. Liaise with local residents. Good Housekeeping on site. Clean High Vis PPE worn at all times on site.
5	Dust, Animal Droppings, Grease, Food waste etc	Buildings.	Yes	On discovery of excessive dust, animal droppings, grease, food waste etc, works must stop and management / supervisor to make a decision as to whether they would be able to safety clean and dispose of it. If not, then it must be reported to the Openreach management team who will arrange for the area to be cleaned.
6	Confined Space Environment	All sites	Yes	Ensure that supervisors / managers have sufficient experience and have been trained to be able to recognise a confined space, - including when a non-confined space would change to a confined space due to their / others activities. All confined space work to be undertaken must follow the HSE guidance L101 (Safe Work in Confined Spaces).
7	People falling into open manholes.	All sites	Yes	Follow the guidance as prescribed by NRSWA paying particular attention that all open manhole must have sufficient protection around them at all times and that gases test testing is to be undertaken



8	Disturbance caused - noise, lighting	All sites	Yes	Ensure that adhere to the time restriction given for noise / lighting. The Local Authority's environmental Health Officer will be kept informed of all upcoming activities that may impact local residents. All plant and machinery will be switched off when not in use. All plant and machinery will be maintained and serviced to minimise noise. Dust reduction measures to be employed if necessary.
9	Explosion, Electrocution and/or Burns	Plant or Works close to Overhead Lines, Exposed Electric Cables, Underground Electrical services. Private land where utility information is unregulated.	Yes	Refer to PU Prints, Contact Utility if request on plans prior to works commencing. Mark up Services, Detection Equipment used on site (Cat & Genny). Stop work and inform relevant utility immediately if damage occurs. Highly visible barriers should be erected at least 6 m away from overhead lines to prevent inadvertent approach to them. Crossing points beneath the overhead lines need to be clearly defined by means of red and white goalpost and signs. On private land, utility information is often out of date or unrecorded / not regulated. Use safe digging and construction methods on private land.
10	Danger of Explosion and/ or escape of noxious gases- Risk of damage caused to underground services	Exposed Gas duct, Underground Gas services Private land where utility information is unregulated.	Yes	Refer to PU Prints. Contact Utility if request on plans prior to works commencing and Mark up services prior to work commencing. Stop work and inform relevant utility immediately if damage occurs. On private land, utility information is often out of date or unrecorded / not regulated. Use safe digging and construction methods on private land.
11	Danger of being struck by Train	Works near railways. Level Crossings	Yes	Method statement required. Liaise with the railway operators
12	Ignition of Hazardous Fumes	Works near Petrol Station, Landfill sites. Gas Leak	Yes	Liaise with local businesses e.g. Petrol Station. No smoking or use of mobile phones near to the site. Gas testing prior to start of works and constant monitoring of gas levels required.
13	Danger of Flooding and / or Drowning	Existing Water Main Works close to river, lakes, lochs, sea	Yes	Rescue crews and equipment available on site, to be operated by trained and competent personnel only..
14	Inhalation of toxic gas and oxygen deficiency Asphyxiation caused by contamination	Confined Spaces e.g. Tunnels, Manholes, Trenches/Excavations Contaminated Land, Landfill sites	Yes	Gas Monitoring equipment available on site. Follow a safe system of work. Rescue procedures should be instructed prior to work commencing. Rescue crews to be deployed as required. Only trained and competent personnel (Minimum requirement Confined Space Entry and emergency escape with 5 minute escape set) to be deployed. No Lone Working under any circumstances.
15	Drilling through existing utilities while Drilling through walls and slabs	Masonry Wall Concrete Wall	Yes	Liaise with Building Manager. Ensure that worker is familiar with utilities plans and have undertaken further checks to be satisfied that there are no services prior to drilling. Mark up Services/Cables prior to work commencing.
16	Slips, trips and falls	Poor re-instatement, Damage to permanent surface, stored materials, trailing hoses or cables, Trailing pipe work	Yes	Remove waste and rubbish as it arises. Good Housekeeping. Provide NRSWA, Chapter 8 signing and guarding. Adequate barriers and equipment on site. Liaise with local residents/emergency services.



17	People struck by vehicles entering or leaving the site		Yes	Use a Banksman. Clean High Vis PPE worn at all times on site. Provide NRSWA, Chapter 8 signing and guarding. Adequate barriers and equipment on site. Liaise with local residents/emergency services. All vehicles must be driven/operated/towed in an appropriate way with safe loading of the vehicle
18	Physically / Verbally Threatening Behaviour	Known trouble spots. Anywhere	Yes	Treat members of the public politely. All verbal or physical threatening behaviour from residents, members of the public or third parties must be report to the Openreach management team who will report it through the Openreach Accident / Incident reporting system. These must also be reported to their own contractor management.
19	Evidence of Discarded Medicines / Needles - infection caused by any of these.	These can be found anywhere. Often sited in around drains, back lanes, Red light districts	Yes	Contact Local Authority Environmental Health Department for their removal. Keep cuts & abrasions covered with an impervious dressing. Wear heavy duty impervious gloves. Good Hygiene practices
20	Hit by falling tools / equipment	Steep Inclines. Narrow working area Work at height	Yes	Good Housekeeping. Equipment / tools should not be stored near the trench or on working platform. Kick boards to be deployed on all working platforms.
21	Working at height	Work on ladders, work on the roofs, work on cherry pickers.	Yes	Ensure that all working at height activities meet the stipulations as set out in the appropriate HSE approved code of practices and guidance's for working at height. They must ensure that an appropriate risk assessment has been undertaken for all working at height activities and that the controls highlighted have been put into place prior to the activities commencing. Any equipment to be used must be; Suitable for the task / environment, Be maintained / checked, Appropriate training given for those who are to use it.
22	Lone Working		Yes	Regular contact between the worker and their supervisor. Check must be made that the worker has returned to their base on completion of the task. Access to adequate First Aid Kit
23	Burning, Temporary Blindness from lasers	Working with live fibres	Yes	Good Housekeeping - removal of sharps . Eye Wash available. Power down all lasers prior to work on working fibres. Deploy Laser Protection Glasses/Goggles where not possible to confirm powering down of equipment. Check for laser deployment using with Live Fibre Identifier but bear in mind that this is not a conclusive test.
24	Woodland Fire		Yes	Leave site immediately. Contact Emergency Services as soon as possible
25	Interference with fire escape routes from surrounding buildings	All sites	Yes	Ensure that the escape routes are not blocked by works or equipment. Where this is not possible the building manager will need to be informed in sufficient time to make alternative arrangements and brief all on site. Provide NRSWA, Chapter 8 signing and guarding. Adequate barriers and equipment on site. Liaise with local residents/emergency services. Clean High Vis PPE worn at all times on site.

26	Danger from Weils Disease (leptospirosis)	Works near lakes, rivers, sewers and other standing water	Yes	Contractor need to ensure that they have briefed all they relevant staff on the necessary precautions to prevent the contraction of Weils disease which should include as a minimum: Keep cuts & abrasions covered with an impervious dressing. Wear heavy duty impervious gloves. Good Hygiene practices. Carry Leptospirosis warning card if working in areas of likely rodent infestation. Notify doctor of possible contact with rodent habitat if reporting with flu like symptoms.
27	Danger from Legionella / Pontiac Fever	Cooling towers, air conditioning systems	Yes	Any illness should be reported immediately. Mask should be work during works.
28	HGV vehicles impact with trench/ personnel	Steep inclines Road Bends	Yes	Provide NRSWA, Chapter 8 signing and guarding. Adequate barriers and equipment on site. Liaise with local residents. Clean High Vis PPE worn at all times on site.
29	Heavy plant toppling into an excavation.	Steep inclines, narrow road/lane	Yes	Stop blocks provided. Never tip over an edge without approved stop blocks. Plant should be located away from trench edges
30	Risk of trench collapse from surcharging	Buildings, banking or other structures increase additional loading to the ground	Yes	Batten back trench sides. Trench Sheeting in Strips Plant, equipment and tools should be located away from the trench edges
31	Interference with structural integrity of building		Yes	Liaise with Building Manager prior to work commencing
32	Traffic Accidents	Areas of congestion. Local Accident Black spots	Yes	Provide NRSWA, Chapter 8 signing and guarding. Adequate barriers and equipment on site. Clean High Vis PPE worn at all times on site.
33	Asbestos (ACM – Asbestos Containing Material)	Buildings constructed or refurbished between 1950 and 1996. Insulating coating on steelwork Lagging on pipes boilers Some decorative plaster Old Firestopping materials Corrugated roofing materials	Yes	In order to avoid asbestos, information must be obtained on the location and condition of asbestos prior to work commencing from the building manager (Asbestos Register) Liaise with the Building Manager during works. Third party contractors to ensure that they have familiarised themselves with the sites asbestos survey in relation to the areas that they will be working. No works to take place if asbestos is present in the areas to be worked in or if there is a risk that asbestos in other areas could be disturbed by the work activities or through the access to the working area. Third party contractors who are working within buildings for Openreach and who are at risk of coming into contact with asbestos materials must have received appropriate training for the identification of asbestos materials. If asbestos / suspected asbestos is discovered then works must stop immediately and be reported to Openreach as soon as possible The Openreach management team will require specific information and may request help from the Openreach Health and Safety Team. Found asbestos / suspected asbestos must also be reported to your own company management team.
34	Listed Building	All site	Yes	Listed Building consent will need to be obtained via the Landlord prior to any work commencing. No deviation to route once agreed should be made without further consents
Planner Name		Completed the above hazard identification sheet in relation to the planned works and surrounding area, based upon the findings during site survey and any guidance from third parties. Further risk assessment may be required.		

Method of Feed & Drop Off		Listed Buildings	
Method of Feed Externally:	UG	Listed Buildings - Freeholder must apply for listed building consent	
Method of Feed Internally:	Internal	Is this a Listed Building?	No
		Has the Freeholder applied for listed building consent?	N/A
		<p>Note: Externally fed MDUs must allow for a L2C journey and inline with the Openreach Build Policy.</p> <p>Provide Listed Building Consent Documentation if required.</p>	
		<p><b>Notes</b></p>	
		 	Listed Build & Method of Feed
Planned by:	LEANNE GULLIFORD		
Date	27/04/2022		

Contact Name on site:		Building Construction Date (Please Select)	Built Since 2000
Does an Asbestos Register exist?			No
IF YES - Are there any known Asbestos issues onsite? (Notes Below)			No
Can the proposed internal route be delivered safely? (Notes Below)			No
Will a refurbishment and demolition survey/ Route Sampling be required?			No
Number of proposed samples required - Detail Below			0
Notes:	 		Asbestos
	Planned by:	Planner Name	
	Date	02/08/2021	

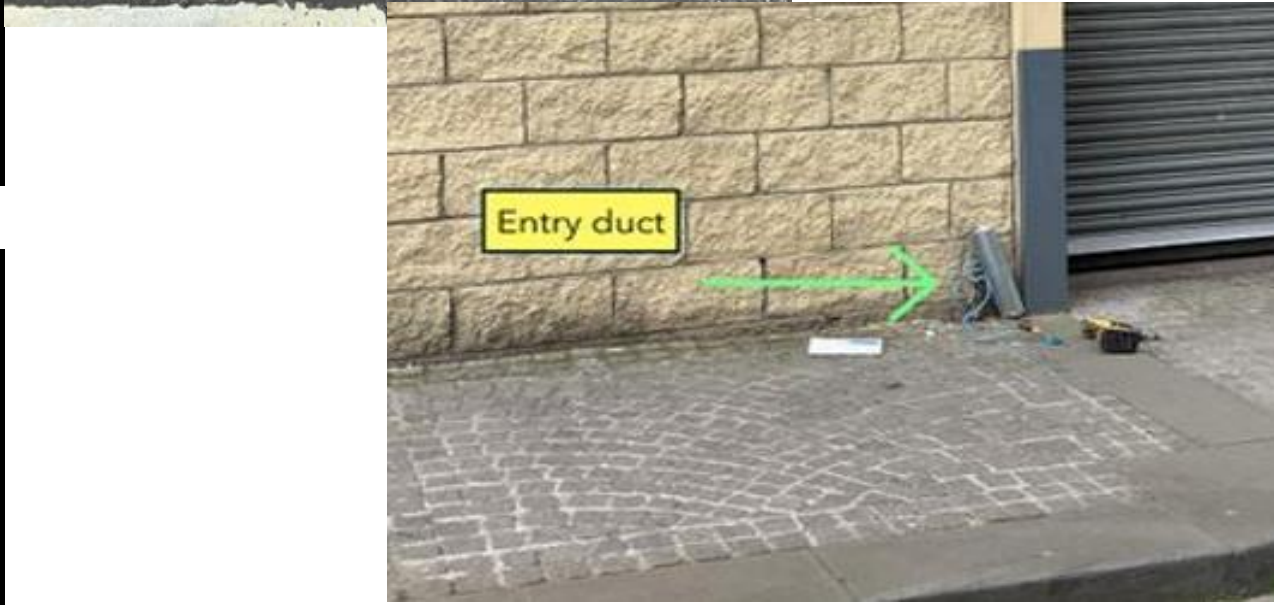

Exchange Name	EDINBURGH WAVERLEY	TM Node / Joint	TMZBJOHC	MDU ID	SM-00005187
Job Description					
Work Address	65/1 - 65/10, Holyrood Road, Edinburgh, EH8 8AU				
Can Rod & Rope Task take place?	NO				
YES? Please provide Photo evidence of Duct and rope					
NO? Provide reason why Rod and Rope cannot take place. Also provide photo evidence & Submit A55	TRR could not be completed, unable to open JRC, hydraulic lifter needed. A55 required				

External				Firestopping	
Item	Proposed	As built	Existing	Proposed	
Cable fixed to wall				Plug	
External U/G Joint				Collar	
Underground Duct				Disc	
Chamber				Masic	
Riser guard				Sleeve	
Overhead Cable					
CBT					
CSP					
Riser					

		<b>Test Rod &amp; Rope</b>
Planned by:	LEANNE GULLIFORD	
Date	27/04/2022	



<b>Exchange Name</b>	EDINBURGH WAVERLEY	<b>TM Node / Joint</b>	TMZBJOHC
<b>Job Description</b>			
<b>Work Address</b>	65/1 - 65/10, Holyrood Road, Edinburgh, EH8 8AU		
<b>Defintion</b>	CIVILS		
<b>Simple/Complex (Please Select)</b>	Simple		

**Notes:** TRR looks to be done already but unable to complete as JRC is on road and unable to open, requires hydrolic lifter and TMA

Item	External		
	Proposed	As built	Existing
Cable fixed to wall			
External U/G Joint			
Underground Duct			
Chamber			
Riser guard			
Overhead Cable			
CBT			
CSP			
Riser			

openreach  
Connecting you to your network

circet  
UK

A55

Planned by:

LEANNE GULLIFORD

Date

27/04/2022

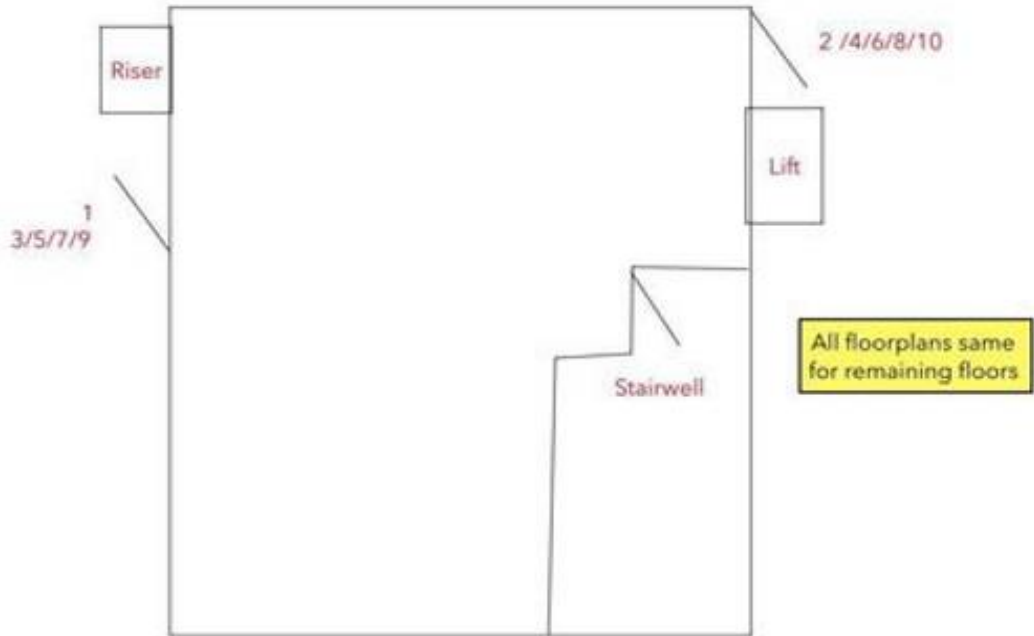

Exchange Name	EDINBURGH WAVERLEY	TM Node / Joint	TMZBJOHC
Job Description			
Work Address	65/1 - 65/10, Holyrood Road, Edinburgh, EH8 8AU		

Notes: GROUND FLOOR - 5TH FLOOR EACH HAVE 2THP, 10THP IN TOTAL

Schematic	
Item	Proposed
Joint	
Basement Box	
Budi Box	
Chamber	
RDT	
CSP	
CBT	



Planned by:	LEANNE GULLIFORD
Date	27/04/2022

Floor Plan

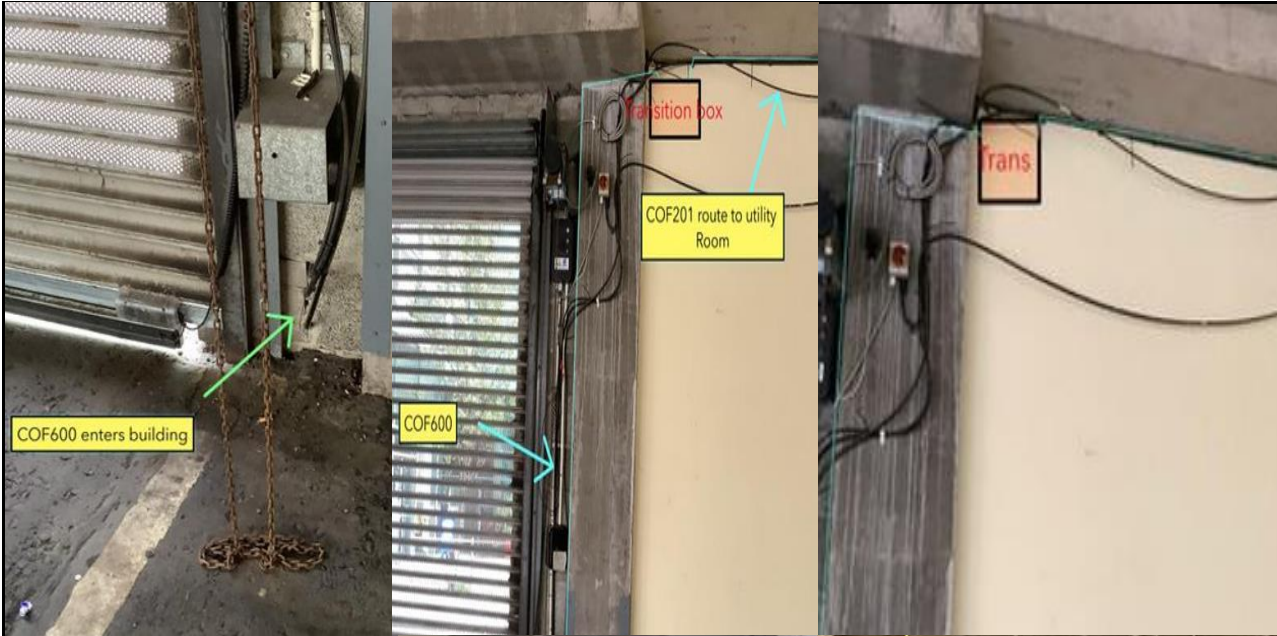

Exchange Name	EDINBURGH WAVERLEY	TM Node / Joint	TMZBJOHC
---------------	--------------------	-----------------	----------

Job Description	
-----------------	--

Work Address	65/1 - 65/10, Holyrood Road, Edinburgh, EH8 8AU
--------------	---

COF600 entry to building, Transition box placement in Garage. COF201 route to utility room.

Entry duct located at side of MDU at garage entrance, transition box installed in garage with COF201 running along garage ceiling to utility room where equipment will be installed, EZ bend route from GF to 1st floor spirals hallway up to riser

COF201 route along ceiling of garage, COF201 entry point to MDU.

External			
Item	Proposed	As built	Existing
Cable fixed to wall			
External U/G Joint			
Underground Duct			
Chamber			
Riser guard			
Overhead Cable			
CBT			
CSP			
Riser			

Internal			
Item	Proposed	As built	Existing
Fibre Cable			
RDT			
Basement or BUDI Box			
EZ Connect Module			
Access Hatch			
Riser guard			
Trunking			
Percussion Drill			

External			
Item	Proposed	As built	Existing
Fibre Cable			
External U/G Joint			
Underground Duct			
Chamber			
Riser guard			
Catenary Wire			
Toby			
Riser			

Firestopping	
Proposed	
Plug	
Collar	
Disc	
Masic	
Sleeve	

Planned by:	LEANNE GULLIFORD
Date	27/04/2022

Survey Template



OBSELETE AFTER ON SITE MEETING.

FROM ENTRY POINT IN CUPBOARD, CABLES TO FOLLOW ROUTE TO MAIN ENTRANCE AREA ABOVE CEILING FOLLOWING EXISTING CABLE RUNS AND UP RISER OPPOSITE LIFTS ON GROUND FLOOR. SMALL HATCH MAY BE REQUIRED FOR ACCESS PURPOSES IN MAIN ENTRANCE AREA. OR, CABLE TO COME IN TO CUPBOARD THEN BACK OUT TO OUTSIDE BUILDING REQUIRING SMALL SECTION OF EXTERNAL TRUNKING THEN BACK INTO BUILDING ABOVE CEILING LEVEL

PLEASE CALL STEWART DEAKIN FOR ON SITE MEETING AT TIME OF BUILD TO WALK AROUND AND CONFIRM

<b>Exchange Name</b>	EDINBURGH WAVERLEY	<b>TM Node / Joint</b>	TMZBJOHC
<b>Job Description</b>			
<b>Work Address</b>	65/1 - 65/10, Holyrood Road, Edinburgh, EH8 8AU		
<b>1</b>	EZ Bend route from cupboard to riser through hallway, PVC trunking required.		
<b>2</b>	EZ Bend cable route from RDT on ground floor through riser system to all floors and POEs.		
<b>3</b>	Exact same cable route and layout throughout.		



Internal				External			
Item	Proposed	As built	Existing	Item	Proposed	As built	Existing
Fibre Cable				Cable fixed to wall			
RDT				External U/G Joint			
Basement or BU/DI Box				Underground Duct			
EZ Connect Module				Chamber			
Access Hatch				Riser guard			
Riser guard				Overhead Cable			
Trunking				CBT			
Percussion Drill				CSP			
				Riser			

Firestopping	
Item	Proposed
Plug	
Collar	
Disc	
Masic	
Sleeve	



**Cable Route**

<b>Planned by:</b>	LEANNE GULLIFORD
<b>Date</b>	27/04/2022

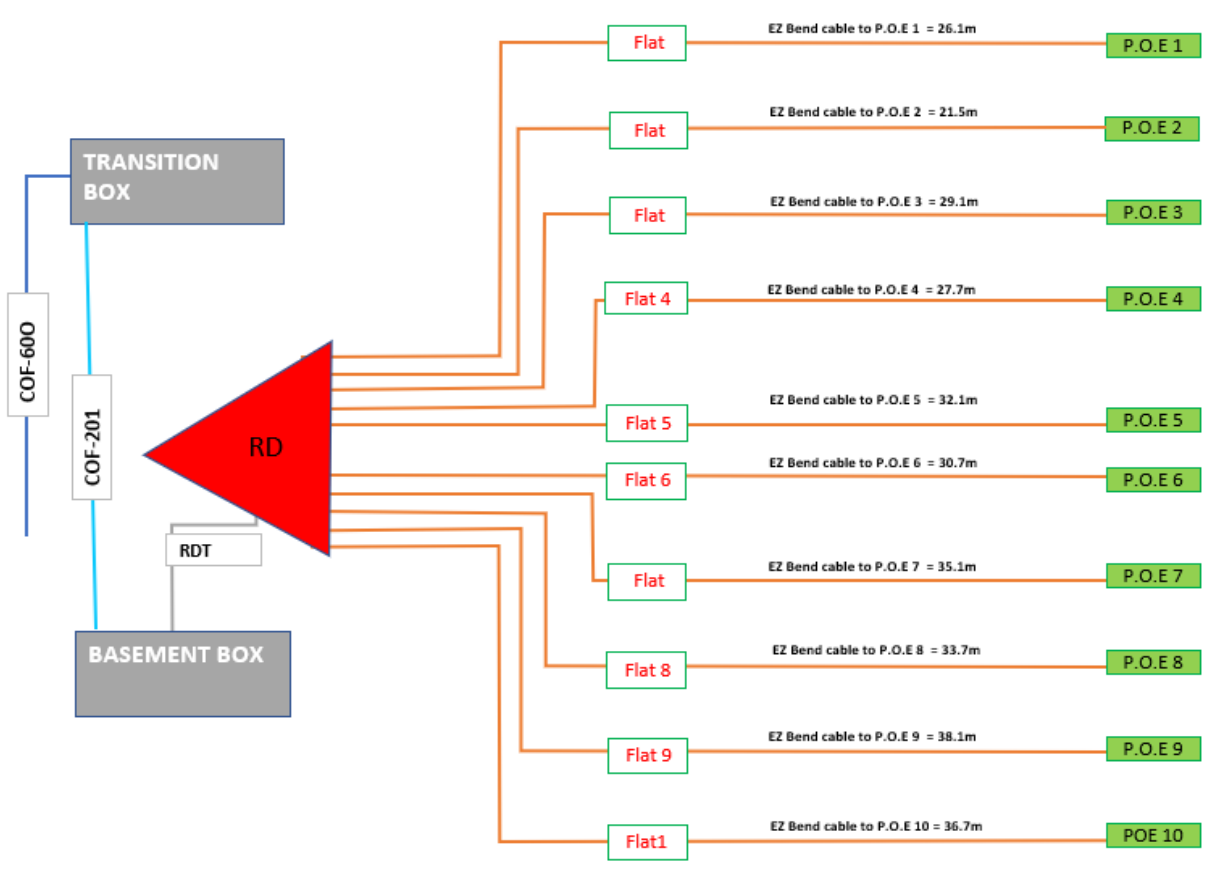



Exchange Name	EDINBURGH WAVERLEY	TM Node / Joint	TMZBJOHC
Job Description			
Work Address	65/1 - 65/10, Holyrood Road, Edinburgh, EH8 8AU		

Schematic	
Item	Proposed
Joint	
Basement Box	
Budi Box	
Chamber	
RDT	
CSP	
CBT	

Internal			
Item	Proposed	As built	Existing
Fibre Cable			
RDT			
Basement or BUDI Box			
EZ Connect Module			
Access Hatch			
Riser guard			
Trunking			
Percussion Drill			

Planned by:	LEANNE GULLIFORD
Date	27/04/2022

Schematic

CODE	DESCRIPTION	COMMENTS	ITEMS REQUIRED
94784	MDU FTTP 12 way Fully Connectorised Floor DP (Connectorised Tail)	RDT WITH CONECTORISED END	1
94410	MDU FTTP basement Splicing Box (non splitter)(xcpsc03154)	PRYSMIAN BASEMENT BOX	1
94814	MDU FTTP EZ Bend Dual Ended Connectorised 4.8mm cable 7m	7M E Z BEND CABLE WITH CONECTOR AT EACH END	11
94815	MDU FTTP EZ Bend Dual Ended Connectorised 4.8mm cable 10m	10M E Z BEND CABLE WITH CONECTOR AT EACH END	9
94816	MDU FTTP EZ Bend Dual Ended Connectorised 4.8mm cable 15m	15M E Z BEND CABLE WITH CONECTOR AT EACH END	11
N671	Optical Joint (up to 24 fibres)		10
N676	Optical Joint Fibre Splicing		1
N67K	Management of up to 12 Fibres onto Tray		1
N67W	Connection of Fibres in Connectorised node / joint		1
N67X	Introduce cable into internal Fibre node (MDU)		1
N683	Fibre Insertion Loss Testing		10
94787	MDU FTTP Apartment Compact Connectorised Break Out Pack	RESIDENTIAL INTERNAL INSTILATION KIT	10
94786	MDU FTTP Corridor Connectorised Break Out Pack	BREAKOUT BOXES COME IN PACKS OF 12	1
94828	MDU FTTP Connectorised Customer Connect Fibre Reel	RESIDENTIAL INTERNAL INSTILATION KIT	10
TBC	Fire Stopping Compund no 2	USED FOR HOLES LARGER THAN 6 MM	1
96381	Safe D clips size 3		2
96385	Stainless steel cable ties Size 3		2
TBC	Wall Dogs		1
N36R	MDU Build less than 24 THP		10
N413	Provide/Repair Duct Seal		1
N63A	Installation of COF600 cable in the underground ducted network		1
N65A	Install an Internal Fibre DP (Serves up to 30 Plots)		1
		THP	10
Notes:	 		Bill Of Materials
	Planned by:	LEANNE GULLIFOR	
	Verified by:	27/04/2022	

# Screen shot of FIRAS certification

openreach  
Connecting you to your network

Planned by: LEANNE GULLIFORD

Date: 27/04/2022

FIRAS

Up to 30 Prems (Res) – Splitter **outside** Building – **No Ceiling**  
Space for cabling

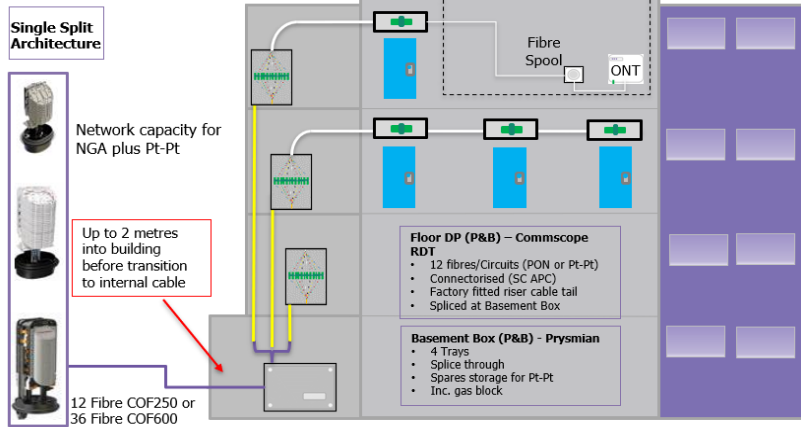

Up to 30 Prems (Res) – Splitter **outside** Building – **Ceiling Space**  
for cabling

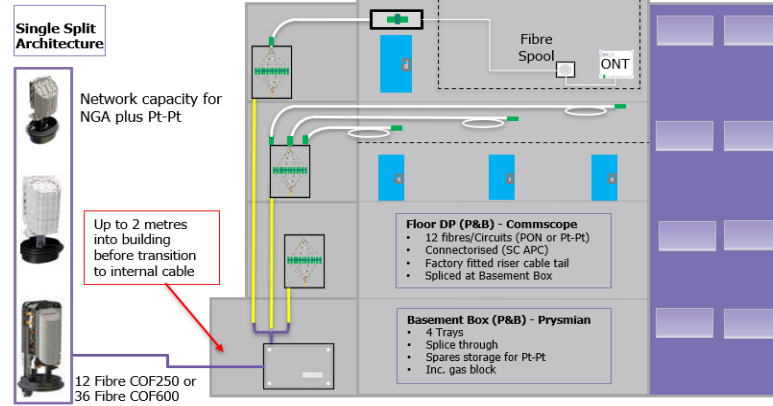

31 to 60 Prems (Res) – Splitter **inside** Building – **No Ceiling**  
Space for cabling

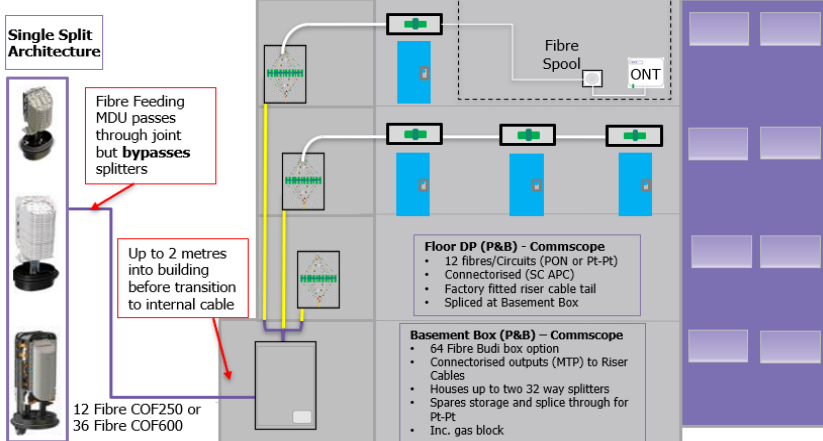

31 to 60 Prems (Res) – Splitter **inside** Building – **Ceiling Space**  
for cabling

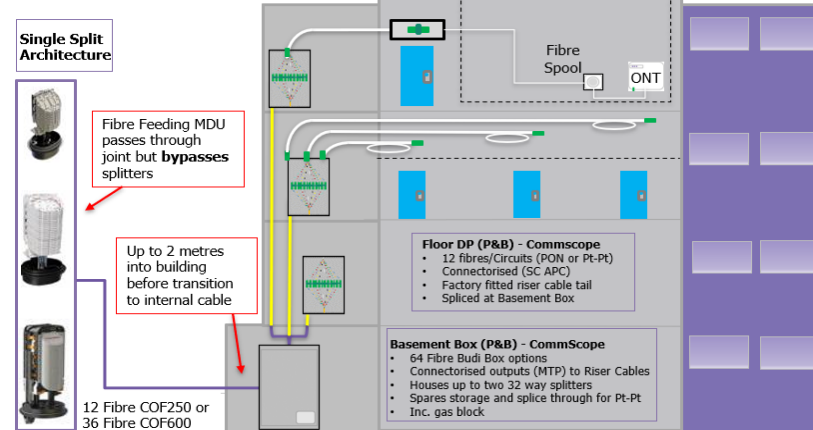

**Budi Box**



**Prysmian**

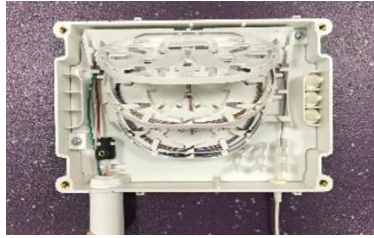

**Floor DP - RDT**



**EZ-Bend Cable**



**Point of Entry**



**openreach**  
Connecting you to your network

Planned by: LEANNE GULLIFORD

Date: 27/04/2022

Material

## InvisiLight® EZ-Connect™ Solution (Residence)

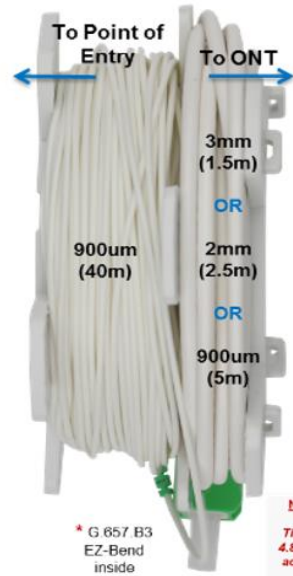
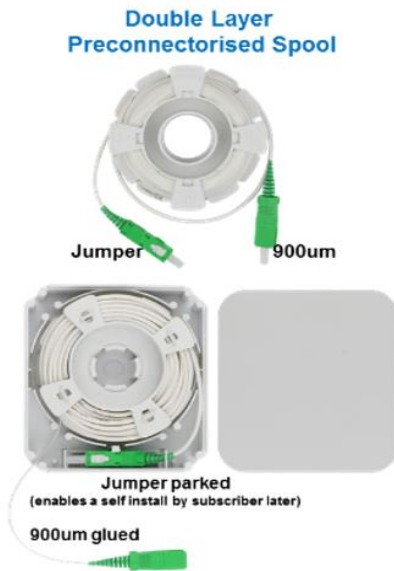

**NOTE** - Furcation tubing is used to emulate a 2mm or 3mm jumper. This prevents a splice from 900um to a 3mm or 4.8mm jumper on the spool. It also eliminates an adapter and the preconnectorised jumper used today.



**Point of Entry (POE)  
Cover and Base**

 Connecting you to your network		Material
Planned by:	LEANNE GULLIFORD	
Date	27/04/2022	

### EZ-Bend Ruggedized Cable

- EZ-Bend G.657.B3 Optical Fiber with a 2.5mm bend radius -twice as tight as the industry standard.
- backwards compatible with G.652.D fiber,
- offered as factory-connectorized and tested assemblies or Reel-in-the-Box,
- 3.0mm or 4.8mm diameter ruggedized cordage including a tonable option,
- 100 lb pull tension, enabled by aramid strength members
- rated for indoor distribution, outdoor including underground and risers,
- can be secured using zip ties, staples or clips,
- plenum and dual-rated low-smoke zero-halogen (LSZH) construction with fire ratings including UL, Plenum and Europe CPR (Construction Products Regulation) certification



EZ-Bend Cable

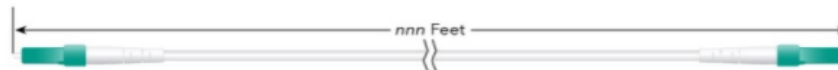

**openreach**  
Connecting you to your network

Planned by: LEANNE GULLIFORD

Date: 27/04/2022

Material



**openreach**  
Connecting you to your network